

COVERMATE III

Plastic Bracket

Installation instructions

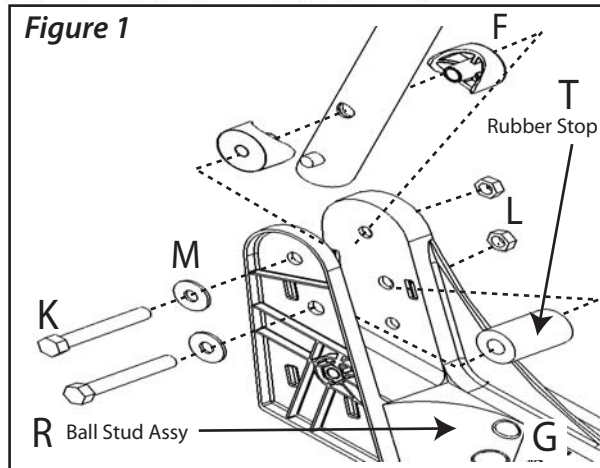

Step #1

Position the spa cover (in closed position) on the spa. Making sure that all four corners are properly positioned and square on the spa.

Step #2

Install the rubber stop, bolt assembly and ball studs on the left and right brackets (see Fig.1)

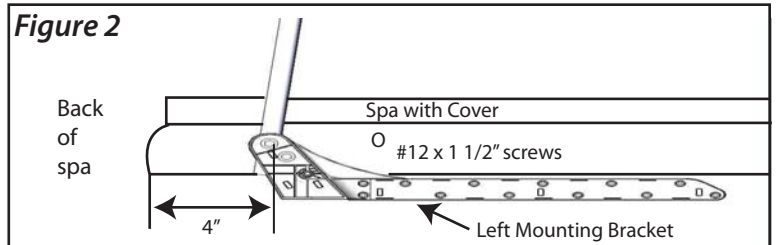

Step #3

Using the #12 x 1 1/2" screws, attach the left and right mounting brackets to the appropriate sides of the spa (see Fig. 2)

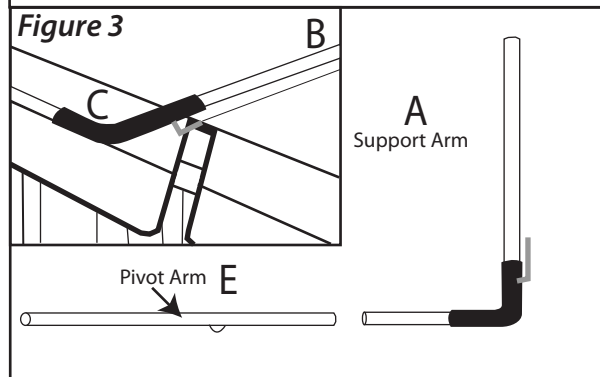

Step #4

Starting with the left side first, lay the long end of the cover support arm on the top of the cover, lying parallel to the spa cover hinge about 1/2" away. Insert the U-shaped retainer clip in between the two cover halves with the horizontal part touching the underside of the cover hinge (see Fig. 3). With the left support arm lying on the cover, slide the straight coupler piece over the long end of the left cover support arm. Next, slide the long end of the right support arm into the center coupler making sure that the U-shaped retainer clip is inserted in between the two cover halves with the horizontal part touching the underside of the cover hinge.

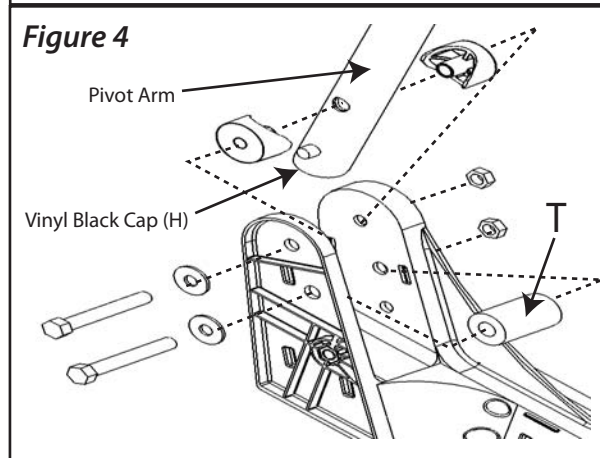

Step #5

Slide the left and right pivot arms onto the short end of the support arms. Then connect the pivot arms to the brackets (see fig. 3 & 4).

NOTE: Do not insert self-tapping screws at this time. This will be completed in step # 8. Be sure to run the bolt head as pictured. Lightly tighten the bolt so that the pivot can move freely.

NOTE: Over tightening may lead to failure of bracket.

Step #6

Next install the wind lock bar on the determined bracket side. (see Fig. 5). Lightly tighten nut, washer and bolt combination so that the lock bar moves freely.

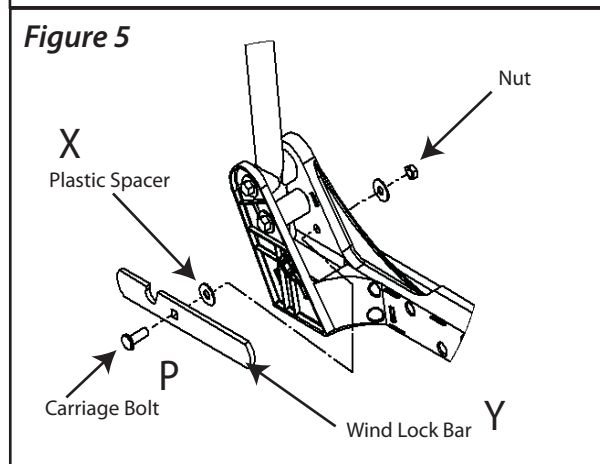

Step #7

Next, install the ball studs to the left and right pivot arms. Note: Be sure that the ball is pointing away from the spa. (see Fig. 6).

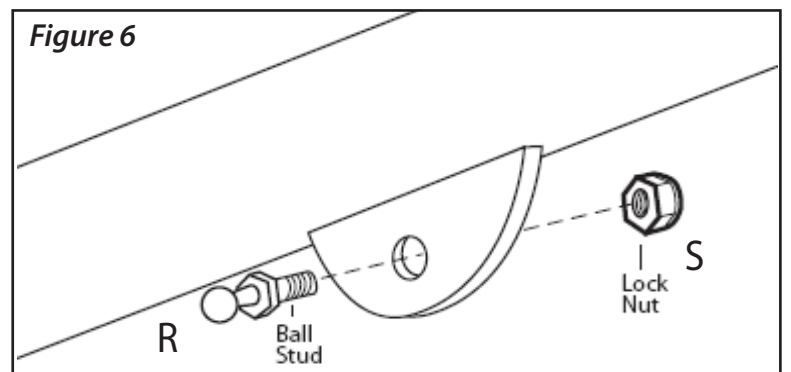

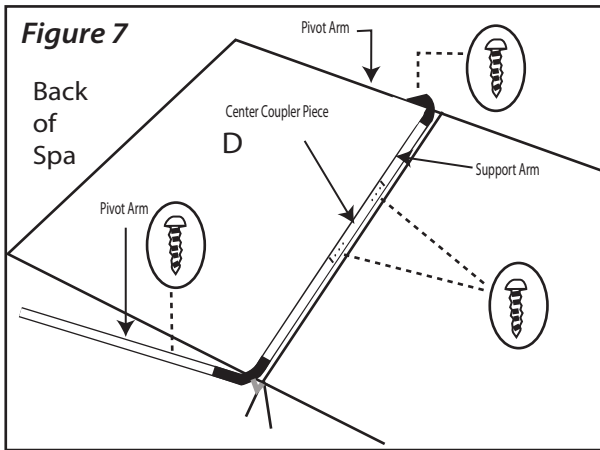

Step #8

With the coupler piece and support arms adjusted properly (about 1/2" away from cover hinge and centered on spa), using the #10 self tapping screws, fasten support arms to pivot arms and center coupler piece to the support arms (see fig. # 7.). *Note: Be sure to rotate the coupler piece so that the inserted screws are at a horizontal angle with the screw head facing the back of the spa.*

Step #9

Using the Covermate, lift the cover off the spa and place it in the upright position. Snap the gas shocks on the ball studs.

Note: Be sure to install Gas Shocks with the black body on top. (see fig. 8 for complete look).

Step #10

Attach 3/8" Rubber Sleeve to the end of the Pivot Arm that the Wind Lock Bar latches onto. (See Fig. 9)

Attach the provided 3 hook TowelMate on the preferred side of your Covermate by simply snapping it into place and inserting the middle self tapping screw (See Fig 10)

Step #11

Snap on the left and right bracket covers (front and large covers). (See Fig. 11)

You Are Done - Operation of the Covermate III Plastic

1. Fold the first half of the spa cover off the spa. Gripping the rubber grip. Motion the spa cover into its vertical upright position

2. When closing spa cover unlock Wind Lock Bar by lifting up on the bar and pulling the Covermate down.

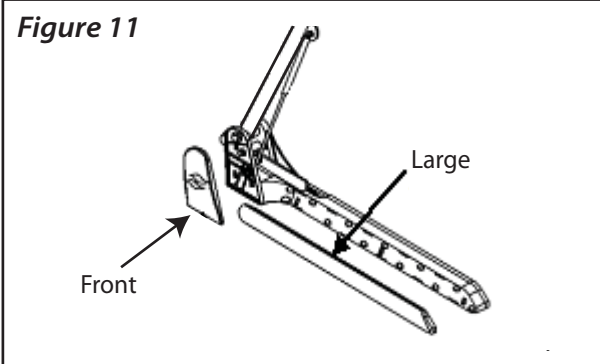
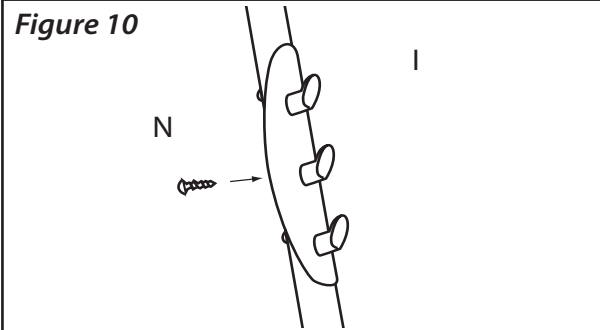
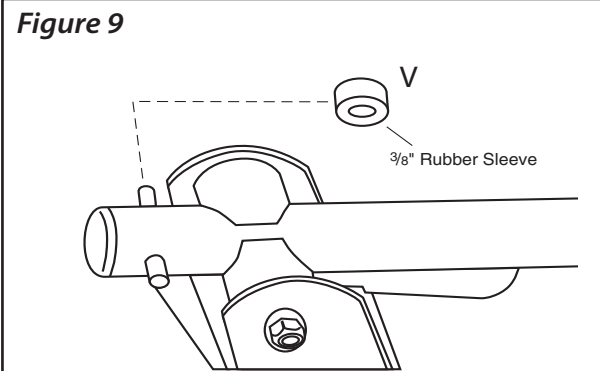
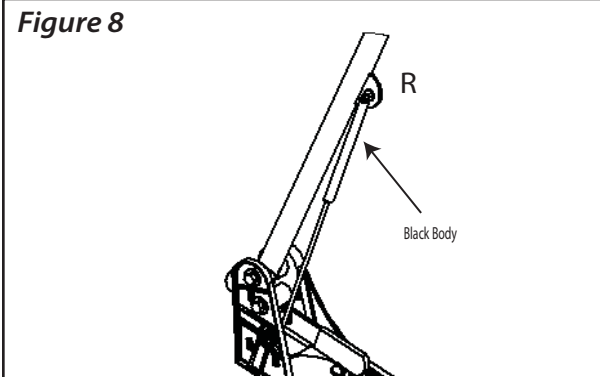

CAUTION!

Do not use the Covermate in high wind condition (greater than 10 m.p.h.). Injury from the spa cover being blown over and impacting the spa user can occur.

ITEM	Part #	Box Content - Description	QTY
A	100028	1 1/8" x 4'10"; 20x40-PAINTED RETAINER RIGHT	1
B	100029	1 1/8" x 4'10"; 20x40-PAINTED RETAINER LEFT	1
C	100002	8" GRIP	2
D	100003	1 1/8" x 3' 7"; COUPLER -PAINTED	1
E	100022	1 1/4 x 2' 7"; PIVOT ARM ASSEMBLY-PAINTED	2
F	100344	BUSHING, Plastic Black .8825" Thick	4
G	100023	CM III PLASTIC BRACKET KIT	1
H	100024	1.250" x 1.750" Vinyl black Cap	2
I	100008	TOWELMATE	1
J	100025	CMIII PLASTIC SCREW KIT	1
K	100026	3/8-16 X 2 3/4" Hex Cap Screw	4
L	100011	3/8-16 Thin Nylon INS Locknut	5
M	100012	3/8 USS Flat Washer	5
N	100013	#10 x 5/8 Phillips Pan-Self Tapping screw	12
O	100027	#12 x 1 1/2" Phil Pan screw - mounting	24
P	100031	3/8-16 X 1 CARRIAGE BOLT GR 2 BLACK ZINC	1
Q	100016	Small black dome cap	12
R	100031	5/16-18 BALL STUD BLACK	4
S	100032	5/16-18 THIN NYLON INS L/N ZINC	4
T	100033	RUBBER SLEEVE 1.85"; 1.25" O.D.; .45" I.D.BLK	2
U	100034	HEX PLASTIC CAP DOME BLACK, 5/16	2
V	100035	RUBBER SLEEVE .33" I.D. X .59" O.D. X .38" LONG	1
W	100030	CM III PLASTIC INSTRUCTION SHEET	1
X	100370	Plastic Spacer, .38 I.D. x .75 O.D. x .093 thick	1
Y	100055	Lockbar, .250" thick	1